

X-Green

by SteelKor

Solutions For Food Safety



X-Green by SteelKor

Solutions For Food Safety

The cleaning and sanitization processes at the food preparation stage of the distribution channel (field to fork) must be improved AND food-handling behaviors must be changed. SteelKor's X-Green System is intended to do just that. The System injects Fit Fruit & Vegetable Wash, into an agitated cold water bath to eliminate dirt, grime, residues, waxy build-up, and most importantly, **MICROBES** and **BACTERIA** that cause food-borne illnesses.

The systems in the marketplace today are either too large or too small for food preparation applications. The X-Green System allows food preparation personnel in a commercial kitchen environment to clean and sanitize large amounts of produce in a short period within a small footprint.

The X-Green System is an integral part of an overall food safety program that creates a systematic, well thought out approach to food preparation. The System not only cleans and sanitizes produce, but also provides a mechanism to assess and monitor adherence to a food safety program. This comes by way of a produce labeling function that prints key sanitization data and the system's statistical reporting capabilities. This allows operations managers or food safety directors the ability to assess proper utilization of the equipment to assure program compliance.

CLEANING PROCESS

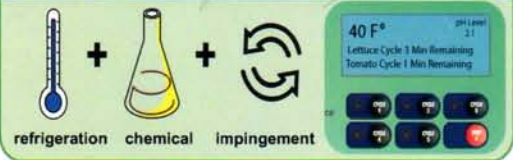

INTELLIGENT CONTROL CENTER:

- Consistent results with micro processor technology
- Programmable produce cycles
- tailored to your operation
- Delivers the proper amount of chemical via pH monitoring
- Statistical Data storage and reporting function

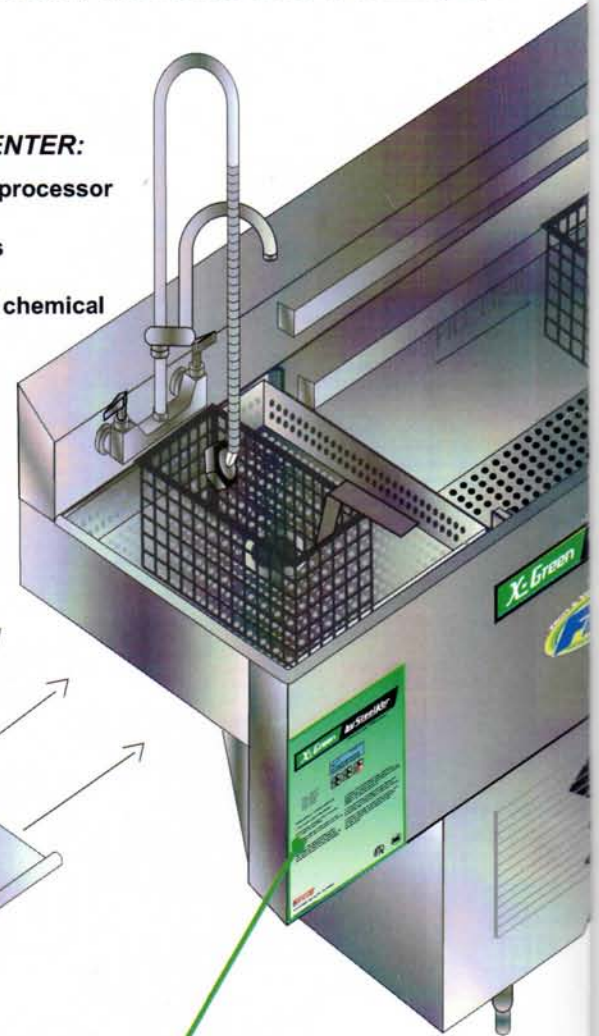

OPTIONAL SALAD SPINNER AND DRAINBOARDS:

- Salad spinner removes remaining water from leafy produce
- Drainboards provide staging and produce preparation work surfaces

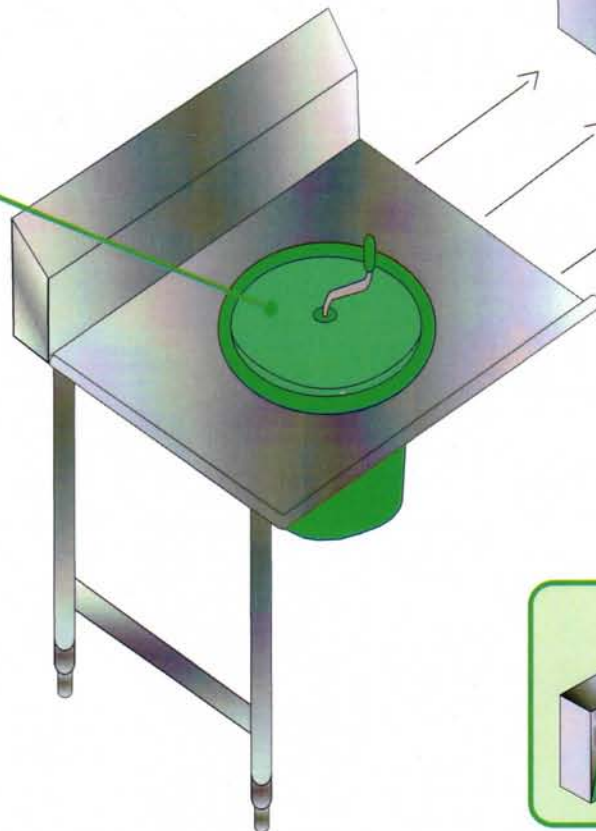

PLUG "N" PLAY SERVICE:

- All main components can be replaced
- Replacements require no service call needed
- SteelKor overnights replacements
- 3 year parts and 1 year labor



Patents Pending

X-GREEN'S CORE FEATURES AND BENEFITS

- :Crisping:** chills water to 40° F for crisping
- :Agitation:** creates surface friction on the produce to assist wash agents in cleaning and sanitizing
- :Wash Agent:** automatic injection of Fit, produce wash agent to assure proper concentration and pH levels
- :Labeling:** prints labels with key sanitization data for placement on produce, storage containers, or for customer viewing and awareness
- :Statistical Reporting:** provides management with key data to monitor compliance with the food safety program
- :Basketing:** allows produce of differing types to be cleaned simultaneously, allows for smaller batches, and provides ergonomic transfer
- :Timer:** alarm indicates when produce has been sanitized for prescribed period
- :Water Filtration:** reduces the amount of food particles and soils in the wash tank

OPTIONAL REMOVABLE CUTTING BOARD:

- Provides produce preparation cutting surface

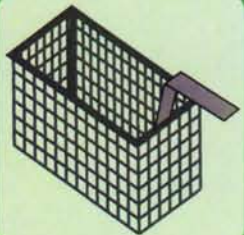

BASKETS WITH LIDS:

- Produce of differing types can be cleaned simultaneously
- Allows for smaller batches
- Ergonomic transfer of produce

X-Green's Wash Action

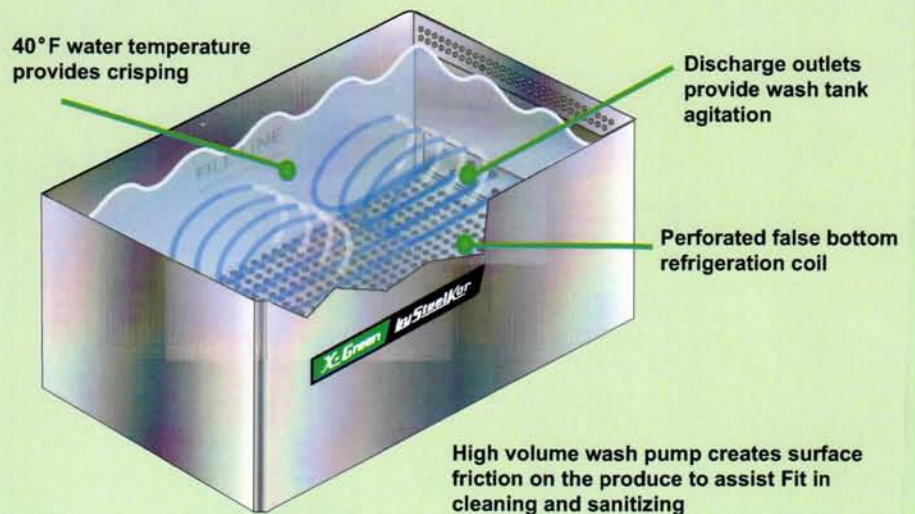

PUMP AND COMPRESSOR:

- Optional compressor chills water to 40° F for crisping
- Wash action pump creates agitation and surface friction for better cleaning results

MAINTENANCE:

Can be replaced in 5 minutes or less by a nut driver and/or wrench,

Replacement parts available for warranty



SteelKor endorses and recommends Fit Fruit & Vegetable Wash for use in the X-Green Produce Safety System. Fit is the only all-natural produce cleaner that can deliver antibacterial benefits to processed produce (cut, chopped, peeled, etc.). Other products on the market are considered harmful chemicals that come with very alarming warning labels. Would you want to eat produce that has been washed with something that is considered corrosive? What about something that will cause severe chemical burns to the skin or eyes? Or something that suggests you wear rubber gloves, a chemical mask, and protective clothing? What if it said harmful or fatal if swallowed? We're pretty sure you wouldn't want that type of chemical being used to wash the produce your consumers eat.

Only Fit is made from 100% Natural ingredients like Citric Acid and Grapefruit Oil...not harmful chemicals. Make sure that your operation, and the places you choose to eat, are using the one and only all-natural fruit & vegetable wash, Fit!

Fit Antibacterial Fruit & Vegetable Wash kills **99.9% of harmful bacteria** - like E. Coli, Salmonella sp., Staphylococcus aureus and Listeria - that have been associated with food-borne illness, and is recommended for use on cut, chopped, sliced and other processed produce. Fit is **100% Natural**, and unlike chlorine or other harsh chemicals, is completely safe to use. Fit rinses away clean, leaving no aftertaste or smell...just the taste and nutrition that nature intended.

Fit is the only produce wash **certified Kosher** by the Orthodox Union, **certified vegan**, and recommended by the American Vegetarian Association. Fit is also endorsed by the Metabolic Code Diet and recommended by Laura LaValle, Registered Dietitian and Chief Clinical Nutritionist for the LaValle Metabolic Institute.

If you are a food service operator, Fit can serve as an integral part of your Food Safety Program/HACCP Plan. If you are a consumer, look for restaurants and other establishments that use Fit to make sure that your produce is cleaner than nature intended.



PRODUCE COMPARISON

Washed with water

Washed with Fit



Tell the world

Fit provides your food service operation with more than just cleaner produce. Fit can also be used as an effective marketing tool with your patrons. Fit is a brand that is available in a consumer format at over 8,000 grocery stores across the country. Your consumers know the brand, use the brand at home, and trust its ability to deliver on its promise of cleaner produce. Fit provides food service operations with marketing collateral to help communicate your commitment to food safety. HealthPro Brands, producer of Fit, offers table tents, sneeze guard stickers, logos for use on menus, and more. Tell your consumers that you care about the cleanliness of the food you serve them. Give them a reason to select your establishment over another. Tell your consumers you use Fit!

Product Labeling:

X-Green produces labeling and statistical data to assist in assuring the public that best practices have been used to protect the public.

Window Cling



Sneeze Guard Sticker

Table Tent



Date 08-13-08
Time 2:31 PM
Wash Time 4 min
pH level 2.8

X-Green *by SteelKor*



Fit is the ONLY produce wash that is certified kosher



Certified Vegan and Recommended by the American Vegetarian Association