

Wood Stone



DESIGNER SERIES

Stone Hearth Oven



Job Name	
Model	WS-DS-7248
Item#	

DESIGNER OPTIONS

- Designer or standard sizes
 - Designer or standard shapes
 - Designer Modules including:
 - Stone Hearth Oven
 - Gas Charbroiler
 - Wood Charbroiler
 - Rotisserie
 - Pita/Flatbread Oven
 - Viewing Windows (typical dim: 12" x 20")
 - Multiple flame location choices
 - Custom Oven-Mounted Exhaust Hood
 - Transport/Rigging Casters
 - Configured for Wood Burning
- Note:** Wood burning models must be vented for solid fuel.
- Prepared for facade application
 - Designer Finishes
 - Shelves and Pan Rails

Wood Stone's Designer Series Stone Hearth Oven provides Wood Stone's legendary performance and reliability in a flexible package offering unparalleled possibilities for those desiring a customized oven to fit their needs.

The foundation of the Designer Series is its multi component modular construction. This allows the capability to integrate a variety of options such as additional oven openings, viewing windows, and oven mounted Charbroilers.

The Designer Series utilizes Wood Stone's signature 4-inch thick, single piece, monolithic cast ceramic floor for superior heat retention and durability. The stone hearth oven modules also integrate a 47,000 BTU, thermostatically controlled infrared burner mounted under the floor which ensures constant floor temperatures.

The insulated wall and ceiling panels are made with a 3-inch thick cast ceramic. The dense high-temperature ceramic formulation of the floor, wall and ceiling panels creates a "deep heat sink" within the chamber of the oven.

Designer Series ovens must be vented using a Type 1 exhaust hood constructed and installed in accordance with all relevant local and national codes. Additionally, Designer Series models with a -W in the model number must be vented as solid fuel appliances.

Wood Stone

An ongoing program of product improvement may require us to change specifications without notice.
Revised January 2009

WOOD STONE CORPORATION

1801 W. Bakerview Rd.
Bellingham, WA 98226 USA

Toll Free (800) 988-8103

Tel (360) 650-1111

Fax (360) 650-1166

info@woodstone-corp.com or visit www.woodstone-corp.com



DESIGNER SERIES

Stone Hearth Oven

Model
WS-DS-7248

Front View

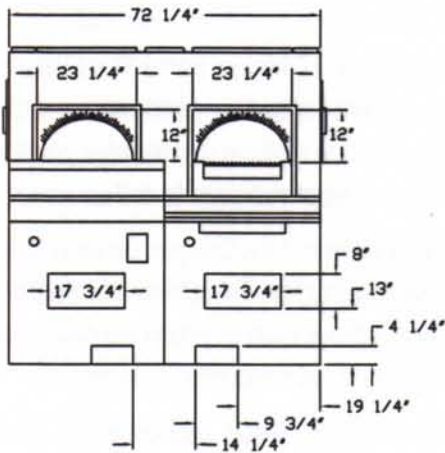

Side View

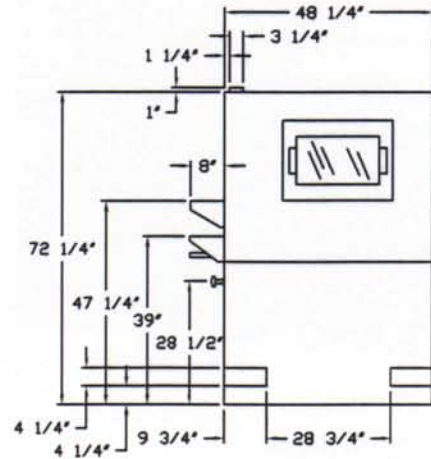

Top View

- Electrical Hook Up - Configurable Left or Right
- 3/4" NPT Gas Inlet - Configurable Left or Right

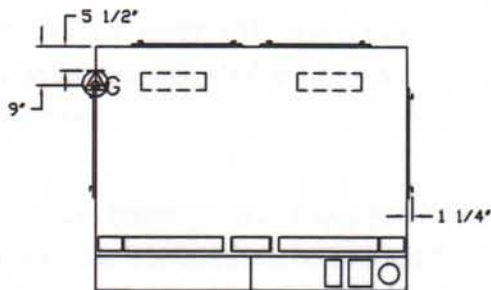

Back View

Viewing Windows (Possible Locations)

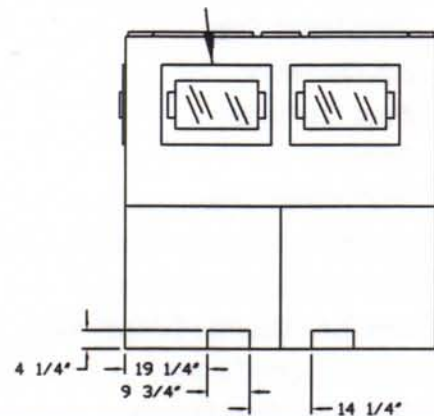

UTILITIES SPECIFICATIONS-VARY DEPENDING ON OVEN CONFIGURATION

IR Burner(each)-47,000 BTU
 Radiant flame burner(each)-50,000 BTU
 Gas-fired Broiler(each)- 57,000 BTU

Electrical

120 VAC, Less than 5A

VENTING INFORMATION

Type 1 hood Required

CLEARANCES

side clearance: 1 inch
 back clearance: 1 inch
 top clearance: 12 inches

Shipping Weight: 4200 lbs.



An ongoing program of product improvement may require us to change specifications without notice.
 Revised January 2009

WOOD STONE CORPORATION

1801 W. Bakerview Rd.
 Bellingham, WA 98226 USA

Toll Free (800) 988-8103

Tel (360) 650-1111

Fax (360) 650-1166

info@woodstone-corp.com or visit www.woodstone-corp.com

Wood Stone



BROILER OVEN CAPACITY:

The Broiler Oven comes standard with (2) 29.5" x 30" cooking grates, resulting in 885 square inches of cooking area for each grate. The upper grate is typically used for slower cooking items like roasted vegetables, fish and larger roasted meats. The lower grate is used for items requiring extremely intense heat - like steaks and seafood items.

OPTIONAL ACCESSORIES

- Dual Compartment Ash Dolly
- Top Grate models available
- Custom Door and Cabinet Finishes
- Firebreak Cap

CHARCOAL BROILER OVEN

Wood Stone Jospier Charcoal Broiler Oven



Job Name	
Model	WS-CBO-3738
Item#	
Fuel Type	Charcoal-Fired

The Wood Stone CBO-3738 Charcoal Broiler Oven provides an elegant solid fuel charcoal broiler/oven solution in an oven package and without the venting challenges most often associated with conventional Charcoal Charbroilers.

The unit comes with two adjustable broiler racks that allow the chef to cook a wide variety of meats and vegetables in the oven simultaneously; making this versatile piece of equipment capable of very high production.

By combining the features of an enclosed oven with the traditional characteristics of charbroiled cooking, this piece offers efficiency in utilizing the heat produced by the charcoal. The dual damper system helps minimize charcoal consumption while allowing the unit to maintain high cooking temperatures for extended periods of time, and helps to greatly influence and enhance the flavor profile of the foods being cooked.

The oven sits on a heavy-duty stainless steel cabinet that incorporates an easily removable ash collection system. The unit also ships with an oven mounted firebreak, poker, brush and grill tongs. Other accessories are available.

The Broiler/Oven is ETL Listed with an 18 inch side and 6 inch back clearance to combustible construction.

The Jospier by Wood Stone Charcoal Broiler Ovens must be vented with a Listed Type 1 exhaust hood or one constructed in accordance with all relevant local and national codes. The oven must be vented as a solid fuel appliance, and in accordance with all relevant local and national codes, and in a manner acceptable to the authority having jurisdiction. See installation manual for additional information.



Wood Stone

An ongoing program of product improvement may require us to change specifications without notice.
Revised January 2009

WOOD STONE CORPORATION

1801 W. Bakerview Rd.
Bellingham, WA 98226 USA

Toll Free (800) 988-8103

Tel (360) 650-1111

Fax (360) 650-1166

info@woodstone-corp.com or visit www.woodstone-corp.com



CHARCOAL BROILER OVEN

Wood Stone Jospser Charcoal Broiler Oven

Model
WS-CBO-3738

WC-CBO-3738

Front View

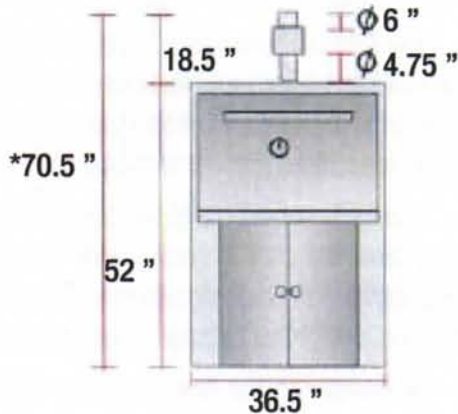

Side View

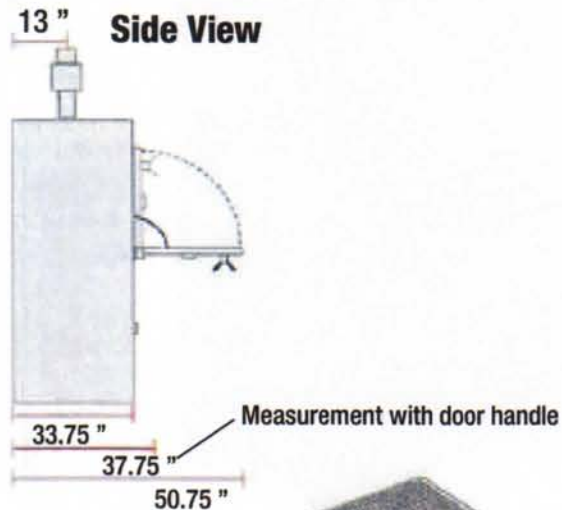

Measurements of cooking grill

* Total height of oven with firebreak

Note: The Wood Stone Jospser Charcoal Broiler Oven (WS-CBO) is also available in a 26" x 28" model (WS-CBO-2628) and a 37" x 28" model (WS-CBO-3728).

VENTING INFORMATION

The WS-JCO models must be vented using a Listed Type 1 exhaust hood, or one constructed in accordance with NFPA 96 and all relevant local and national codes. The oven must be vented in accordance with all relevant local and national codes, and in a manner acceptable to the authority having jurisdiction.

**Unit Shipping Weight:
approximately 900 Lbs.**



Wood Stone

An ongoing program of product improvement may require us to change specifications without notice.
Revised January 2009

WOOD STONE CORPORATION

1801 W. Bakerview Rd.
Bellingham, WA 98226 USA

Toll Free (800) 988-8103

Tel (360) 650-1111

Fax (360) 650-1166

info@woodstone-corp.com or visit www.woodstone-corp.com